

CHLORIDE SYSTEMS

GENERAL DESCRIPTION

Chloride's Tuff-Act wet location and harsh environment exit combines rugged construction and appealing aesthetics. Durable cast aluminum and polycarbonate housing construction, standard vandal resistant/anti-corrosion coated hardware and Intelli-Charge electronics ensures long lasting reliability even in the most severe environments. The Tuff-Act is UL listed for use in wet/damp location applications ranging from -40°F (-40°C) to 113°F (45°C). Tuff-Act exits are shipped with field-selectable chevrons, and can be ordered as a single face or universal (single/double) face configuration. Three color choices are available and stencils may be ordered to match or in an attractively contrasting brushed aluminum finish. Tuff-Act is a Made in the USA product.

ILLUMINATION

Illumination of the exit stencil face is accomplished with long lasting, high output Light Emitting Diodes (LEDs). Hot spots and striations are eliminated by the internal light chamber, which is specially designed around the high performance LED array. Average illumination levels are in excess of 25fl (79 cd/m²).

INSTALLATION

Exit installation methods include top and end canopy mount and back wall mount. All mounting configurations employ neoprene gaskets between exit housing, canopy and mounting surface. The exit is designed to mount to standard 3 1/2" and 4" octagonal junction boxes. Provisions in the cast frame allow for up to two 1/2" flex or rigid conduit points.

DIMENSIONS

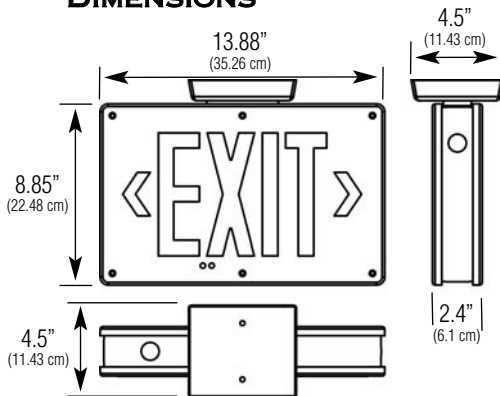

Dimensions are approximate and subject to change.

ORDERING INFORMATION (EXAMPLE: TLN1RBICT)

T	L					ICT	
SERIES	LAMP	BATTERY TYPE	FACE OPTIONS	LETTER COLOR	STENCIL FACE/ HOUSING COLOR	MODEL DESIGNATOR	FACTORY INSTALLED OPTIONS
T = Tuff-Act Wet Location Exit	L = LED	N = Nickel Cadmium A = AC Only	1 = Single Face U = Universal Single/Double Face	R = Red G = Green	W = White Housing and White Stencil B = Black Housing and Black Stencil G = Gray Housing and Gray Stencil WA = White Housing and Brushed Alum. Stencil BA = Black Housing and Brushed Alum. Stencil GA = Gray Housing and Brushed Alum. Stencil	ICT = Intelli-Charge Self-Testing Diagnostic Electronics	A = Audible Diagnostics BF = Buzzer/Flasher (self-powered units only) BZ = DC Buzzer DC = 12-48 VDC Input (AC only models) EX = Special Input Transformer (consult factory) ¹ FA = 24 VDC Fire Alarm Interface FL = Emergency Flasher (self-powered units only) PM = Pendant Mount Only (must order pendant kit accessory) ² SW = Special Wording (consult factory) 2CKT1 = 120 VAC Two Circuit (AC only models) 2CKT2 = 277 VAC Two Circuit (AC only models)

ACCESSORIES (order as a separate line item)

ICIR = Intelli-Charge Infra-Red Remote
T15TPTOOL = Tamperproof Tool
TPKITB = Pendant Kit, 12" Stem, Black
TPKITW = Pendant Kit, 12" Stem, White

Note:

- Some options may impact UL listing. Consult factory for specifics.
- Must specify "PM" option for compatibility with pendant kit.

TYPE: _____

CATALOG NO.: _____

Tuff-Act

Wet/Damp Location, Vandal Resistant Exits
Cast Aluminum/Polycarbonate Construction
AC Only & Self-Powered Models
Standard Self-Testing Diagnostics



SHOWN: TLN1RBICT

HOUSING

Die-cast aluminum housing with premium impact-resistant injection molded polycarbonate covers. Housing is powder coated and back cover is molded in color to match. Front cover is clear. Stencil is provided with field selectable chevrons and is contained inside the fully gasketed housing. All exposed hardware is both vandal resistant and anti-corrosion coated. Universal knockouts on backplate allow wall mounting directly to standard junction boxes. Die-cast aluminum canopy is provided for top/side mounting and is powder coated to match housing. Two knockouts are located on the frame to accommodate 1/2" flex or rigid conduit.

ELECTRONICS

AC Only - 120/277 VAC dual voltage input with surge protection is standard on all models.
Self-Powered - Charging system is microprocessor driven with software embedded diagnostic routine and temperature compensation. See specification sheet C1465 for electronics details.
 120/277 VAC input, surge protection, brownout, AC lockout and low voltage disconnect features are standard.

BATTERY

Maintenance-free, sealed nickel cadmium battery
 Supplies 120 minutes of emergency power
 Estimated service life of 10 years
 Operating temperature range of -40°F (-40°C) to 113°F (45°C)
 Compliant with IEC 61951-1

INTELLI-CHARGE SELF-TESTING DIAGNOSTICS (STANDARD)

The Intelli-Charge diagnostic/charging platform with self-testing mode automatically runs a one-minute self-test every 30 days and a 30-minute test on the sixth and twelfth month. A one-minute or 90-minute test may be initiated via the push to test switch on the unit or by activating the appropriate test command on the optional IR test device.

ELECTRICAL SPECIFICATIONS

AC Only Operation - Input Power Requirements

Red - 3.8 watts (120 VAC), PF = 0.96
 3.8 watts (277 VAC), PF = 0.91
 Green - 4.0 watts (120 VAC), PF = 0.95
 4.0 watts (277 VAC), PF = 0.90

Self-Powered - Input Power Requirements

Red - 4.7 watts (120 VAC), PF = 0.95
 4.8 watts (277 VAC), PF = 0.97
 Green - 4.7 watts (120 VAC), PF = 0.95
 4.7 watts (277 VAC), PF = 0.99

CODE COMPLIANCE

UL 924 listed
 UL damp and wet location listing -40°F (-40°C) to 113°F (45°C)
 NFPA 101, NEC, BOCA, OSHA and IBC illumination standards
 Meets ADA specifications for wall mounted lighting fixtures
 IEC 61951-1 Life Testing (batteries)
 Certified to the California Energy Commission in accordance with California law

WARRANTY

Five-year full electronics warranty.
 Five-year full plus five-year prorated battery warranty.

Specification Data for Tuff-Act Wet Location Exits

HOUSING

Die-cast aluminum housing with premium impact-resistant injection molded polycarbonate covers. A groove molded into each cover accepts a full perimeter silicone rubber gasket.

Housing is powder coated in white, black or grey. On single face units, the back cover is molded in color to match and the front cover is clear. Universal models consist of 2 faces, backplate and canopy.

The stencil is provided with field selectable chevrons and is contained inside the fully gasketed housing.

All exposed hardware is both vandal resistant and anti-corrosion coated.

Universal knockouts on backplate allow wall mounting directly to standard junction boxes.

Die-cast aluminum canopy is provided for top/end mounting and is powder coated to match housing.

ELECTRONICS

AC Only and Self-Powered

Dual voltage 120/277 VAC input with surge protection is standard on all models.

Self-Powered

A dual function indicator light is located on the face of the unit to signify that AC utility is present, as well as indicating the charge status.

The low voltage disconnect (LVD) feature will disconnect the battery prior to an unacceptable deep discharge, but not before the required 90 minute emergency operation.

The brownout protection circuitry will automatically switch the unit into the emergency mode if the utility voltage drops below 85% of nominal.

BATTERY

A maintenance-free, sealed nickel cadmium battery is standard. Construction is of the sintered plate design and the battery assembly is equipped with a quick connect plug assembly for easy installation.

Standard sustained emergency operation is for 120 minutes with the LED illumination source providing full light output.

The approved operating temperature range of -40°F (-40°C) to 113°F (45°C) should provide a service life of 10 years.

The battery is compliant with IEC standard 61951-1.

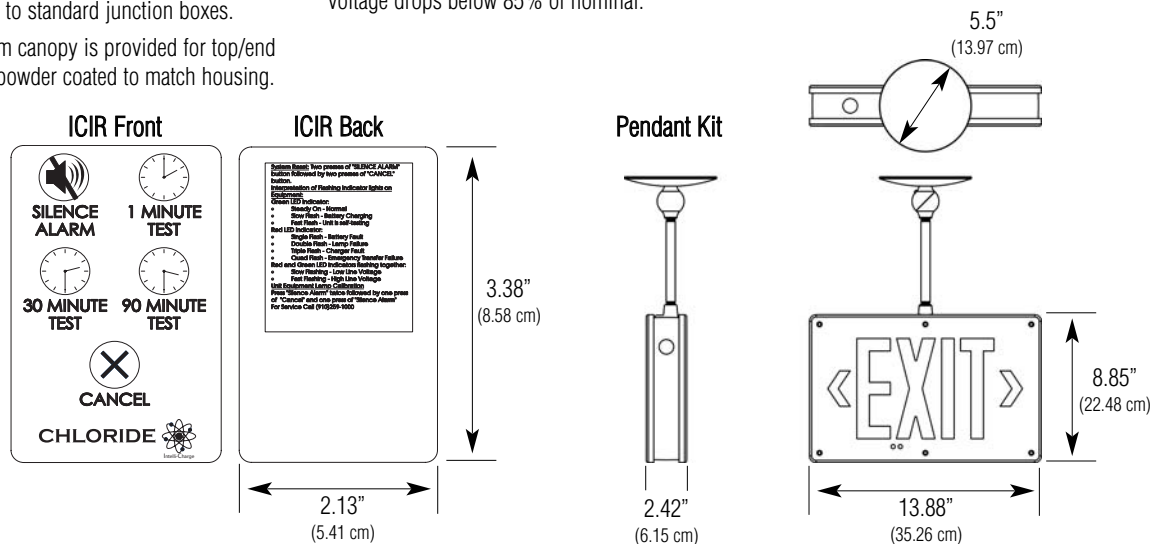

SUGGESTED SPECIFICATION

Furnish and install Chloride's LED exit sign model _____ . The exit shall be constructed to meet Underwriter's Laboratories, Inc. Standard #924 and the National Electrical Code (NEC).

INSTALLATION AND OPERATION – Exit shall be easily field connected to a 120 or 277 VAC, 60 hertz, unswitched power source. Installation must comply with the NEC as well as other applicable codes. (Self-Powered Only) – Upon utility power failure or brown out, the unit shall automatically transfer to battery power and maintain the required illumination level for a minimum period of 120 minutes. Upon restoration of utility power, the charger shall restore the battery to full charge within 24 hours.

ELECTRONICS AC-Only Models – The exit sign shall be easily field connected to 120 or 277 VAC, 60 HZ un-switched power source. The Tuff-Act exit sign equipped with red LED's shall consume 3.80 watts with a power factor of 0.96 (120 VAC) and 3.80 watts with a power factor of 0.91 (277 VAC). The Tuff-Act exit sign equipped with green LED's shall consume 4.00 watts with a power factor of 0.95 (120 VAC) and 4.00 watts with a power factor of 0.90 (277 VAC). Available, factory-installed options shall include a two-circuit module to accommodate 120/120 or 277/277 VAC for use with a generator or central inverter system; A fire alarm activated flasher option to accommodate an input from a fire alarm panel and provide a flashing rate when the alarm system is activated.

Self-Powered Models – All self-powered models shall be provided with Chloride's Intelli-Charge self-testing diagnostics electronics platform. The exit sign shall be easily field connected to 120 or 277 VAC, 60 HZ un-switched power source. Intelli-Charge will detect and notify the installer regarding incorrect wiring of the transformer primary and restrict the damaging effects from affecting the printed circuit board. The Tuff-Act exit sign equipped with red LED's shall consume 4.70 watts with a power factor of 0.95 (120 VAC) and 4.81 watts with a power factor of 0.97 (277 VAC). The Tuff-Act exit sign equipped with green LED's shall consume 4.71 watts with a power factor of 0.95 (120 VAC) and 4.67 watts with a power factor of 0.99 (277 VAC). The Intelli-Charge electronics package shall provide continuous, real-time monitoring of all the critical equipment functions including, but not limited to: line voltage status and condition, charger fault, transfer fault, battery fault, and LED load fault and notify personnel with a visual indicator sequence. Optional audible diagnostics shall be available from the factory. The standard self-testing software shall satisfy the periodic testing requirements in NFPA 101, Life Safety Code as well as the International Building Code (IBC). The Intelli-Charge diagnostic/charging platform with self-testing mode automatically runs a one-minute self-test every 30 days and a 30-minute test on the sixth and twelfth month. The Intelli-Charge circuit shall continuously sample ambient temperature conditions and adjust the charging regime to compensate for typical and dramatic ambient conditions equal to 3mv/°C compensation to maximize the life of the battery. An on-board IR receiver shall be standard and pre-programmed to operate from an optional IR user interface device (available as an accessory item).

BATTERY (Self-Powered Models Only) - The battery shall be maintenance-free, sealed nickel cadmium utilizing sintered plate construction and polypropylene separators for trouble-free operation. The Tuff-Act exit sign shall carry a UL damp and wet location listing for use in ambient conditions ranging from -40° F (-40° C) to 113° F (45° C). The battery shall be tested and recognized in accordance with the accelerated life testing requirements of the IEC standard 61951-1.

ILLUMINATION - The Tuff-Act exit sign shall be illuminated by high-intensity, long-life LEDs. Average legend illumination shall be equal to or greater than 25 fl (79 cd/m²).

ENCLOSURE – The exit sign housing shall be constructed of a combination of heavy-duty die-cast aluminum and injection molded polycarbonate. The final housing finish shall be an epoxy-based, powder coat paint. The exit stencil face shall constructed of aluminum sheet. Chevron selection shall be field selectable using knockouts in the stencil.



CHLORIDE
SYSTEMS

272 West Stag Park Service Road • Burgaw NC 28425
Telephone: (910) 259 1000 • Facsimile: (800) 258 8803
www.chloridesys.com

C1340R11
3/10 IH