

CHLORIDE

Rhyno Series

Industrial Emergency Unit

INSTALLATION AND OPERATING INSTRUCTIONS

Service Questions Call: 910-259-1000

IMPORTANT SAFEGUARDS

When using electrical equipment, basic safety precautions should always be followed, including the following:

READ AND FOLLOW ALL SAFETY INSTRUCTIONS

All servicing should be performed by qualified personnel only.

Equipment should be mounted in locations and at heights where it will not be readily subjected to tampering by unauthorized personnel.

The use of accessory equipment not recommended by the manufacturer may cause an unsafe condition.

Do not use this equipment for other than intended use.

Do not let supply cords touch hot surfaces.

Do not mount near gas or electric heaters.

CAUTION: Halogen cycle lamp(s) are used in this equipment. To avoid shattering: Do not operate lamp in excess of rated voltage, protect lamp against abrasion and scratches and against liquids when lamp is operating, dispose of lamp with care.

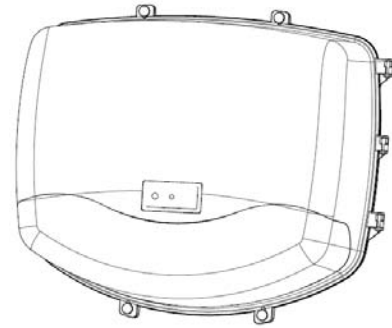

Halogen cycle lamps operate at high temperatures. Do not store or place flammable materials near lamp.

CAUTION: “To avoid electrical overload, total connected lamp load (factory and field installed) should not exceed output rating”.

SAVE THESE INSTRUCTIONS

WARNING – Shut off AC power to branch circuits to which units will be connected. All wiring should be per N.E.C. Articles 501-4(b) and local codes.

To maintain warranty, equipment with batteries must be installed or placed on charge within prescribed period after shipment.

GENERAL INSTRUCTIONS

- 1) Begin the installation process by securing the mounting plate.
- 2) The slotted, circular keyways can be used to secure the mounting plate to a standard

junction box. The junction box must be secured sufficiently to handle the weight of the unit. Additionally, four slotted vertical keyways may be used to attach the mounting plate to independent anchor supports. If wall mounted, run wires through center hole of mounting plate in preparation for unit wiring.

- 3) If the unit is to be mounted to poles or columns, use the optional strapping kit (ordered separately).

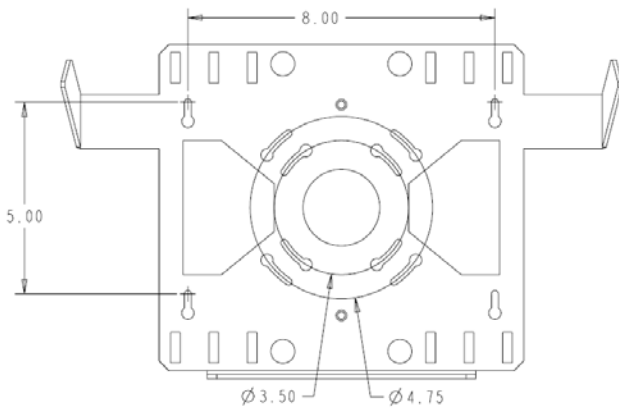

- 4) Once mounting plate is installed, the unit is ready for installation.

To aid in installation, the cover may be removed. To remove cover, disconnect cover membrane switch harness. Open cover 90° and lift. Reverse procedure to return cover to unit. For standard and damp location units that will not see direct water spray, the unit can be wired from the back. Prepare unit by removing circular knockout in the center of the back housing. The unit is now installed by placing the back housing on the two ears of the mounting plate and pivot unit down onto mounting plate. Route wires through hole in the back housing as the unit is pivoted into place.

NOTE: Wet location units must not have the back knockout removed as water will enter the unit. Use U/L listed Wet Location approved conduit or wire cord fittings using removable knockouts on side / top.

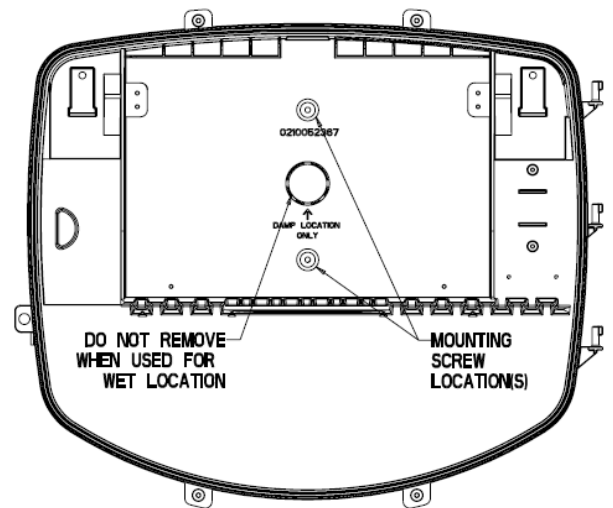

- 5) Unit mounting is completed by installing two screws and rubber washers through the back housing into the mounting plate for security.

INSTALLING BATTERIES

1. Units ship without batteries installed. Unit batteries are shipped separately. Battery wiring harnesses are already connected to PCB assembly. Connection of harness to batteries is required.
2. Install and wire batteries as appropriate. (See Page 6-7 for battery configurations)
3. Tighten straps to secure batteries inside unit.

REMOTE LOAD HOOKUP INSTRUCTIONS

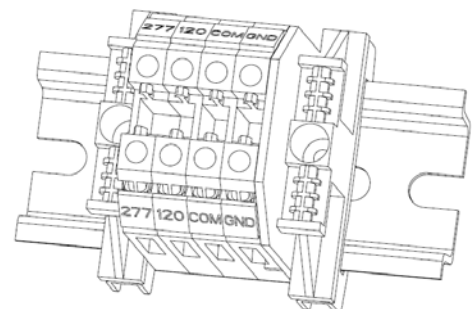

Standard Units:

Connect AC service to unit terminal block.

The unit is pre-wired to accept 120 or 277 VAC. Insert AC service leads and ground wire to appropriately labeled terminal(s). Tighten.

Note for Units with Battery Heater (EE & CA):
The battery heater transformer is pre-wired to the terminal block along with the normal AC unit power. By connecting AC service to the terminal block as above makes AC service connection to the heater as well. No extra wiring is needed for heater operation.

REMOTE LAMP CONNECTION

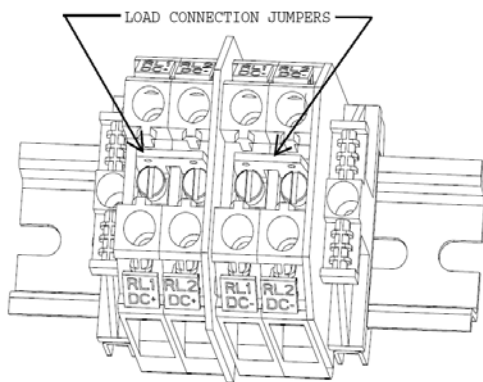

1. A terminal block for the remote lamp loads is provided for easy installation. Two terminals are available for DC+ and DC- each. Units ship from the factory with load connection jumpers installed on both DC+ and DC-. This parallels the load among the unit RL1+ and RL2+ load fuses. Using the jumpers ensures that the total load of the unit is evenly distributed.

2.

REMOTE LOADS WITH LOAD CONNECTION JUMPERS INSTALLED (SMALLER REMOTE LOAD REQUIREMENTS)

1. When using the jumpers, simply subtract the internal lamp total wattage from the unit total wattage and the remainder is the available total remote load capacity. Balancing of RL1 and RL2 is not required as the jumpers perform the remote load balancing.

2. When figuring total load, include the wattage of the internal lamps if applicable and do not exceed unit total wattage capability.
3. EXAMPLE:
A 200 watt unit with three (3) 12 watt lamps connected has 164 watts of remote load capability.

REMOTE LOADS REQUIRING SEPARATE FUSING (LARGER REMOTE LOAD REQUIREMENTS)

1. When it is necessary to independently fuse each set of remote lamp loads, removal of the load connection jumpers is required.
2. Removal of the load connection jumpers is accomplished unscrewing and removing the jumper itself.
3. The terminals are marked RL1 DC+, RL2 DC+, RL1 DC- and RL2 DC-. The terminal blocks are capable of accepting up to #6 wire.

Balancing of the remote lamp loads among RL1 and RL2 is now a consideration and must be planned ahead of time. Determination of allowable RL1 and RL2 maximum capacity depends on whether the unit is configured as a two or three internal head unit as the remote load PCB fuses are shared with the internal lamps. The schematic below illustrates the PCB load routing of the unit where L1+, L2+ and L3+ represent internal lamp loads and RL1+ and RL2+ are the remote lamp loads:

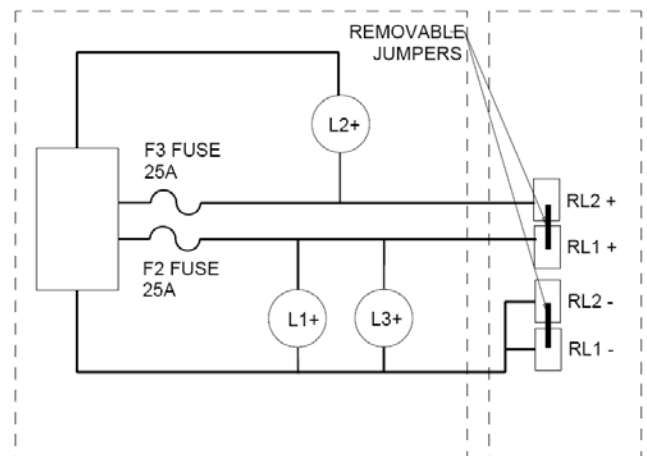

4. Determining allowable remote lamp loads for RL1 and RL2:

- For two head units, subtract twice the lamp wattage rating from the unit total available power. Equally divide the remaining capacity between RL1 and RL2.

- For three head units, internal lamp 1 and internal lamp 3 are on the RL1 fused circuit. Internal lamp 2 is connected to the RL2 fused circuit.

For RL1 circuit, subtract twice the internal lamp rating from half the unit wattage and the remainder is the available remote load capacity.

For RL2 circuit, subtract one internal lamp wattage from half the unit wattage and the remainder is the RL2 remote capacity.

Example:

A 300 watt unit is configured with 3 internal 12 watt heads. The total available wattages for RL1 and RL2 are calculated as follows:

$$\begin{aligned} \text{RL1 Max Watts} &= (\text{Unit Wattage} / 2) - (2 * \text{Internal Lamp Wattage}) \\ &= (300/2) - (2*12) \\ &= 150 - 24 \\ &= 126 \text{ (Watts)} \end{aligned}$$

$$\begin{aligned} \text{RL2 Max Watts} &= (\text{Unit Wattage} / 2) - (1 * \text{Internal Lamp Wattage}) \\ &= (300/2) - (1*12) \\ &= 150 - 12 \\ &= 138 \text{ (Watts)} \end{aligned}$$

Ensure total unit load (including internal lamps) does not exceed unit rating including internal lamp loads.

COMPLETING UNIT INSTALLATION

1. Adjust head(s) to illuminate desired area(s).
2. Close cover and latch. Ensure electrical wires and membrane switch cable remain inside unit and that the cover does not pinch wires when closed. Hand tighten four thumb screws to finalize cover closure. Thumb screws must be used and tightened to maintain a good environmental seal.

OPERATING INSTRUCTIONS

1. Normal Power-Up Sequence

At power-up, the red and green LED indicators will alternately flash for one to two seconds. Next, the unit will go through a “Power-up Quick Test” with the green LED flashing quickly while the lamps are illuminated. If no power-up faults are detected, the green LED will then flash slowly for approximately 36-72 hours to indicate the unit is in a high rate of charge. If any faults are detected during ‘Power-up Quick Test’, these will be indicated by a flashing red LED indicator (Reference Table 2). The red LED will be accompanied by a buzzer if the unit was ordered with the optional Audible Diagnostics. In the event of a unit error, this buzzer may be disabled by a short press of the test switch and will remain disabled for a period of 196 hours (8 days). After the fault has been corrected, the red LED flash and buzzer will be cleared automatically and the unit will return to normal operation.

2. Press and hold the ‘TEST’ button. The lamps should illuminate and the green indicator lamp indicate steady green while the lamps are on.
3. Release ‘TEST’ button. Lamps should extinguish and the green indicator lamp should be steady green if batteries are in maintenance charge or blinking indicating a high rate of charge.
4. Leave A.C. connected for a minimum of 24 hours before performing any abbreviated testing. Full recharge of batteries may take up to 72 hours.
5. Once energized, the unit will wait 36 hours while the batteries are being charged and then perform an automatic lamp load calculation. The system will then detect and indicate a load loss of 10% and indicate a lamp failure. Replace lamps as required. Upon lamp replacement, run any manual self-test and the system will return to normal operating status.
6. If, after installation and calibration, lamp load is increased or decreased the system will need to be manually calibrated for the

new total load. To re-calibrate, press the test switch four times. The unit will illuminate for 30 seconds and then return to normal operation status.

7. Lamp re-calibration can also be accomplished with the optional remote control by pressing in sequence, ‘Silence, Silence, Cancel, Silence’. The lamps will illuminate for a brief time and then return to normal operation status.

SELF-TEST / SELF-DIAGNOSTICS

1. This unit’s charge / discharge circuit is microprocessor controlled. The charging circuit consists of a two stage charging program which will charge the batteries at a high rate of charge and once the batteries approach the correct float voltage, the charger will switch to a maintenance charge mode.
2. The microprocessor controls and detects the following conditions:
 - a. Low Voltage Disconnect (LVD) – Disconnects battery power from unit when battery voltage drops below 87.5% of nominal voltage to protect the batteries from deep discharge.
 - b. AC Brownout – Disconnects the unit from line voltage and transfers the unit to emergency mode when the line voltage sags to 80% or below.
 - c. AC Lock OUT – When line voltage and battery voltage is removed from the unit, the unit will remain off until line voltage is returned. Used to place the unit into hibernation.
 - d. Temperature Compensation – Battery voltage temperature compensation is performed by the microprocessor on a continual basis based on unit ambient temperature conditions.
 - e. Lamp Load Failure Detect – Indicates a load failure when more than 10% of the original load is determined to be removed or lost.

- f. Reverse battery connection polarity.

3. For information regarding failure mode indications, see Failure Codes Table 2 below.

Failure Codes	
Flash Sequence	Failure Mode
1 Flash	Battery Failure – Check battery connections / Replace battery.
2 Flash Red	Lamp load failure – Indication of lost lamp load usually caused by burned out lamps. Replace as required.
3 Flash Red	Charger Failure – Check connections / Replace as necessary.
4 Flash Red	Transfer Failure – Charger has failed to transfer power to lamps during emergency operation. Replace charger.
Flashing Green	Unit has AC applied and indicates unit is in a high rate of charge mode. No action required.
Steady Green	Unit has AC applied and unit is in a normal maintenance charge mode. No action required
Alternating Green / Red (Fast)	Unit connected to higher than allowable voltage. Check line input wiring for correct voltage connections. NOTE: Disconnect power immediately to avoid damage to unit.
Alternating Green / Red (Slow)	Unit connected to lower than allowable voltage. Check line input wiring for correct voltage connections.

4. Manual Test Functions:

Manual Test Procedure	
Test Switch Presses	Test Performed
Press and Hold	Switches the unit to emergency mode and remains in that mode until the user releases the Test Switch.
Single Press	Silences the Audible Alarm Option. The unit will remain silenced until its next normally scheduled check. Discontinues a manual test in process.
Two Presses	1 minute manual test.
Three Presses	90 minute manual test
Four Presses	Lamp load re-calibration. Use if lamp load intentionally changes by addition or subtraction of lamp(s).
Seven Presses	Forces a complete system reset.

Table 1

5. This unit is configured standard with Self-Diagnostics. Periodic checks are performed on the charging circuit, batteries and lamps. Failure of any of these components will result in a red flash to indicate the failure mode (See Table 2 below for failure codes).
6. The Self-Testing option will perform routine maintenance checks in addition to Self-Diagnostics. The Self-Test option runs a 1 minute self-test each month and a 30 minute self-test each 6 months.

Table 2

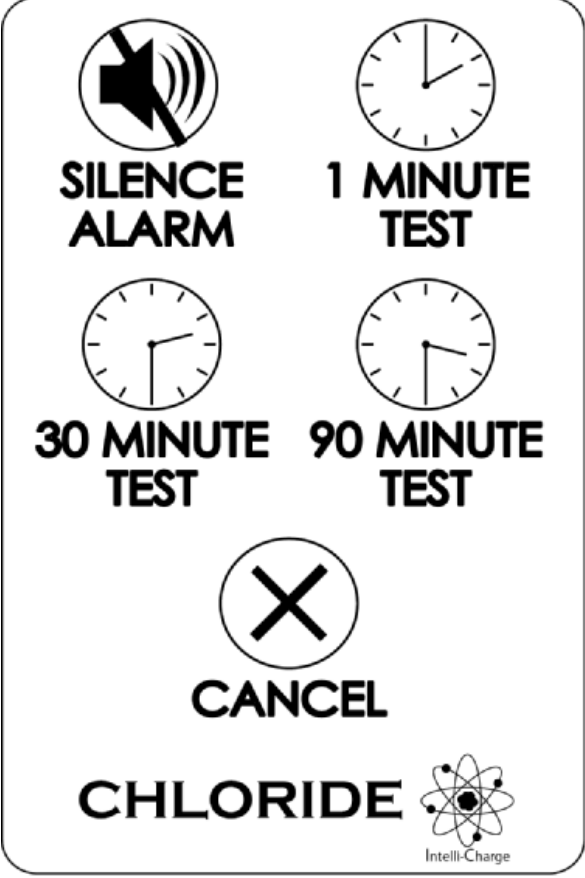
	<p>OPTIONAL REMOTE CONTROL</p> <p>Front</p> <p>Press appropriate button to perform the indicated test or silence the audible alarm.</p> <p>Cancel stops any test currently in process.</p>
	<p>Back</p> <p>Explanation of indicator light flash sequences.</p> <p>Refer to Table 2 above for further information.</p>

System Reset: Two presses of "SILENCE ALARM" button followed by two presses of "CANCEL" button.

Interpretation of Flashing Indicator lights on Equipment:

Green LED Indicator:

- Steady On - Normal
- Slow Flash - Battery Charging
- Fast Flash - Unit is self-testing

Red LED Indicator:

- Single Flash - Battery Fault
- Double Flash - Lamp Failure
- Triple Flash - Charger Fault
- Quad Flash - Emergency Transfer Failure

Red and Green LED indicators flashing together:

- Slow Flashing - Low Line Voltage
- Fast Flashing - High Line Voltage

Unit Equipment Lamp Calibration

Press "Silence Alarm" twice followed by one press of "Cancel" and one press of "Silence Alarm"
For Service Call (910)259-1000

BATTERY HOOKUP DIAGRAMS

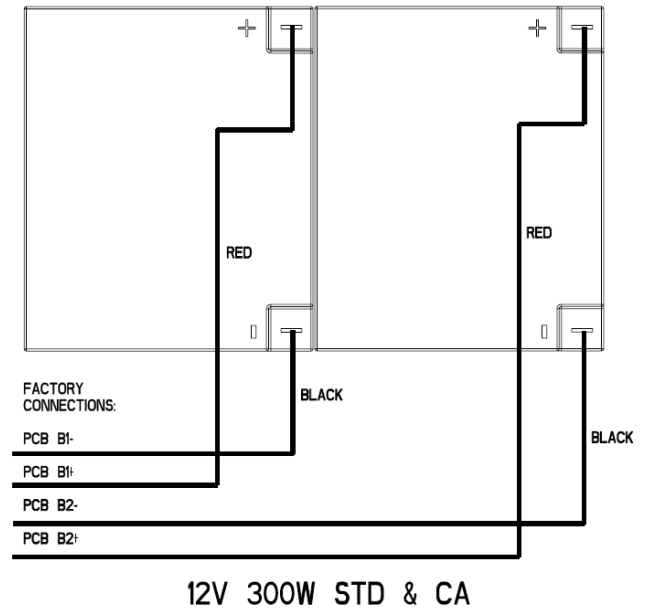
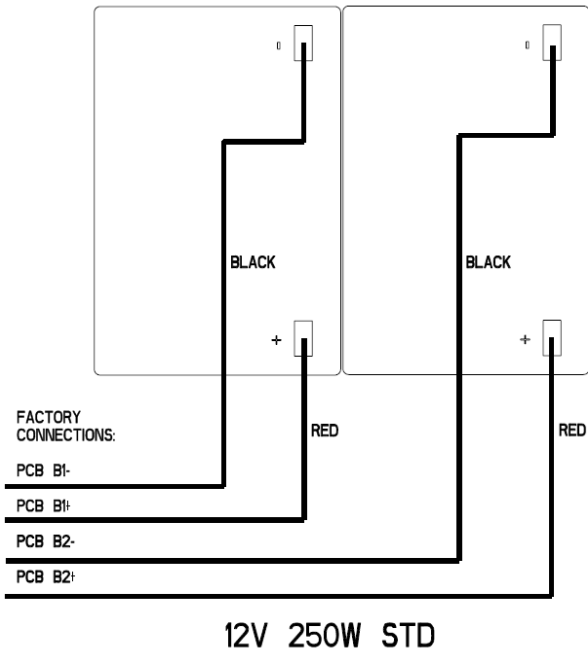
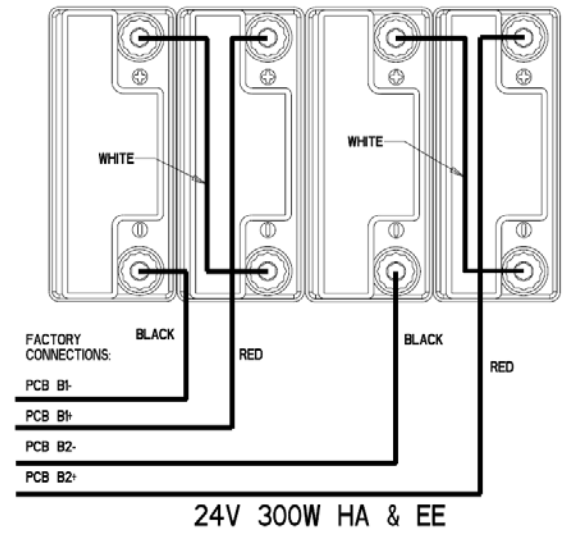
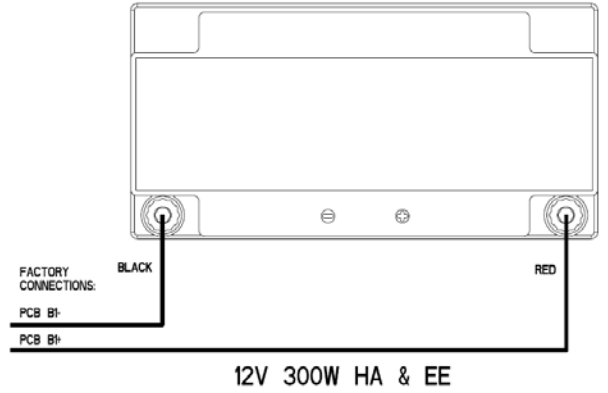
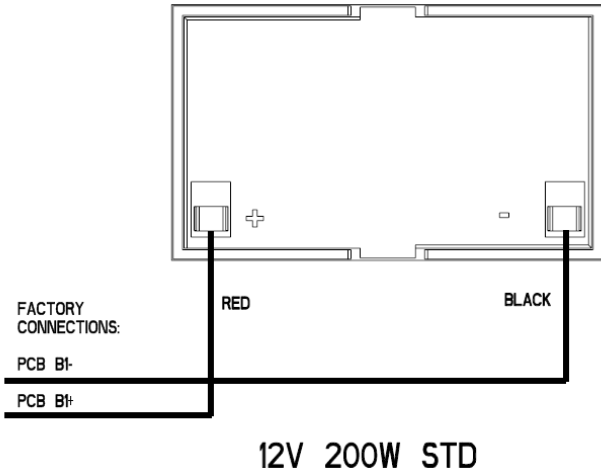

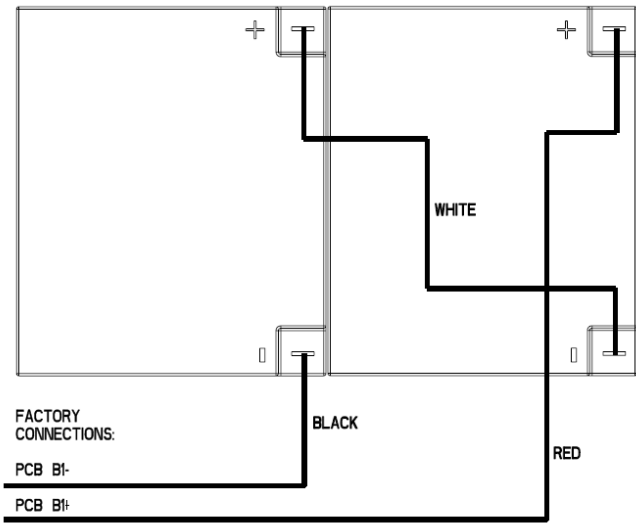

24V 300W STD & CA

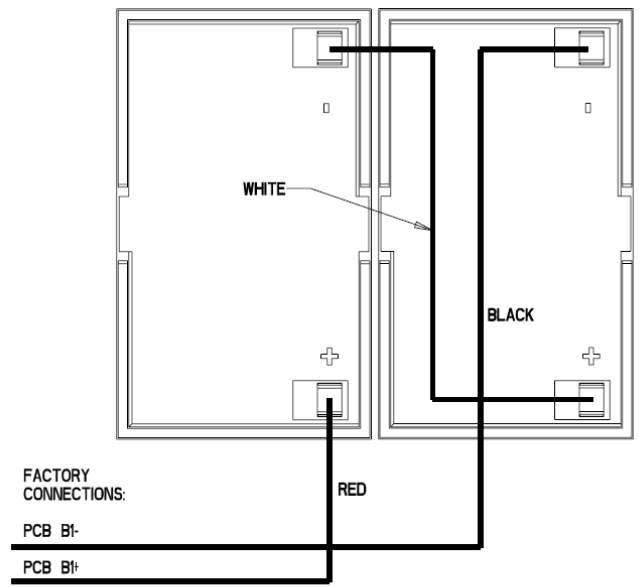

24V 450W STD

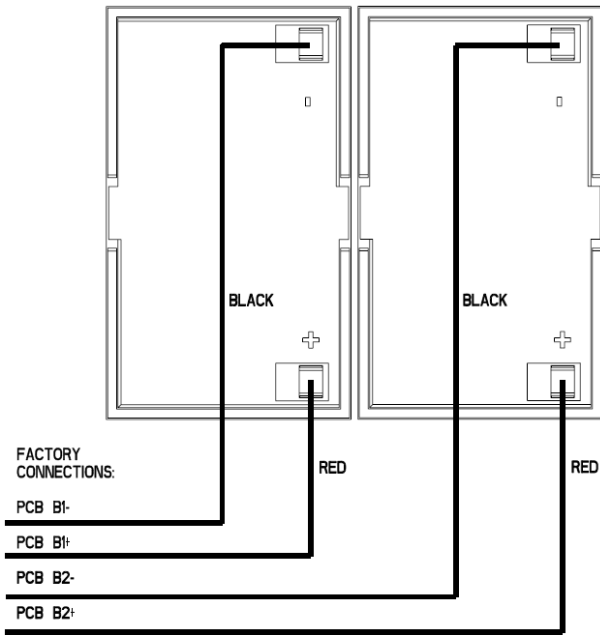

12V 450W STD